

CARMELLO (C-GN)/(C-GN W)



STANDARD EQUIPMENT

- Energy-efficient LED lighting
- Energy-saving refrigerating unit
- Supply of warm air onto the glass
- Rack - RAL 7047 or gold colour
- Electronic temperature controller with digital display
- Feet for levelling the device
- Sliding door
- Dynamic cooling
- Wooden casing
- Illuminated lower front panel
- Defrosting (automatic)
- Automatic condensate evaporation
- Height adjustable display shelves



INTERIOR TEMPERATURE RANGE
+5°C TO +15°C*



DYNAMIC
COOLING



BENT, TILTABLE GLASS



REFRIGERANT 449A



OPTIONAL EQUIPMENT

- Eco leather finishing (front)
- Humidity control system
- Serial connection
- Bogie bumper
- Without casing
- Frame painted in a different RAL colour



ALTERNATIVE VERSIONS



CASHDESK



NEUTRAL
VERSION

Cold

*At an ambient temperature of +25°C and humidity of 60%

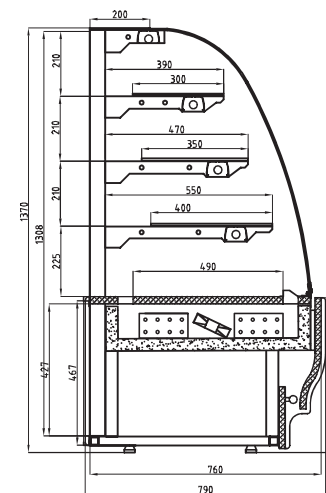
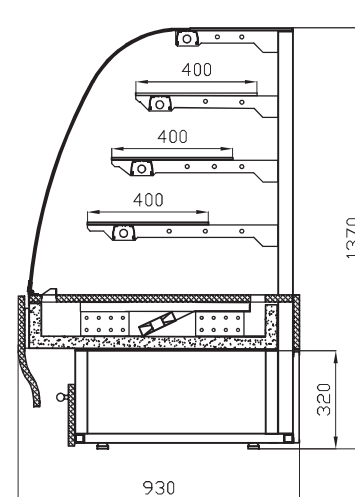

MODULES

Carmello (C-GN): Depth 930 mm

SYMBOL	LENGTH INCLUDING SIDES** [mm]	DISPLAY AREA [m ²]	UNIT	WEIGHT [kg]
C-09 Gn	945	1,65	+	182
C-13 Gn	1345	2,45	+	263
C-17 Gn	1745	3,12	+	320
C-09 Gn B/A	945	1,65	-	162
C-13 Gn B/A	1345	2,45	-	243
C-17 Gn B/A	1745	3,12	-	300

Carmello-w (C-GN w): Depth 790 mm

SYMBOL	LENGTH INCLUDING SIDES** [mm]	DISPLAY AREA [m ²]	UNIT	WEIGHT [kg]
C-09 Gn w	945	1,33	+	172
C-13 Gn w	1345	1,93	+	253
C-17 Gn w	1745	2,52	+	310
C-09 Gn w B/A	945	1,33	-	152
C-13 Gn w B/A	1345	1,93	-	233
C-17 Gn w B/A	1745	2,52	-	290



Cooling capacity requirements at $t_a = -15^\circ\text{C}$: 500 W/linear meter

*At an ambient temperature of +25°C and humidity of 60%

