

# Model SP-40HA & SP-40HI

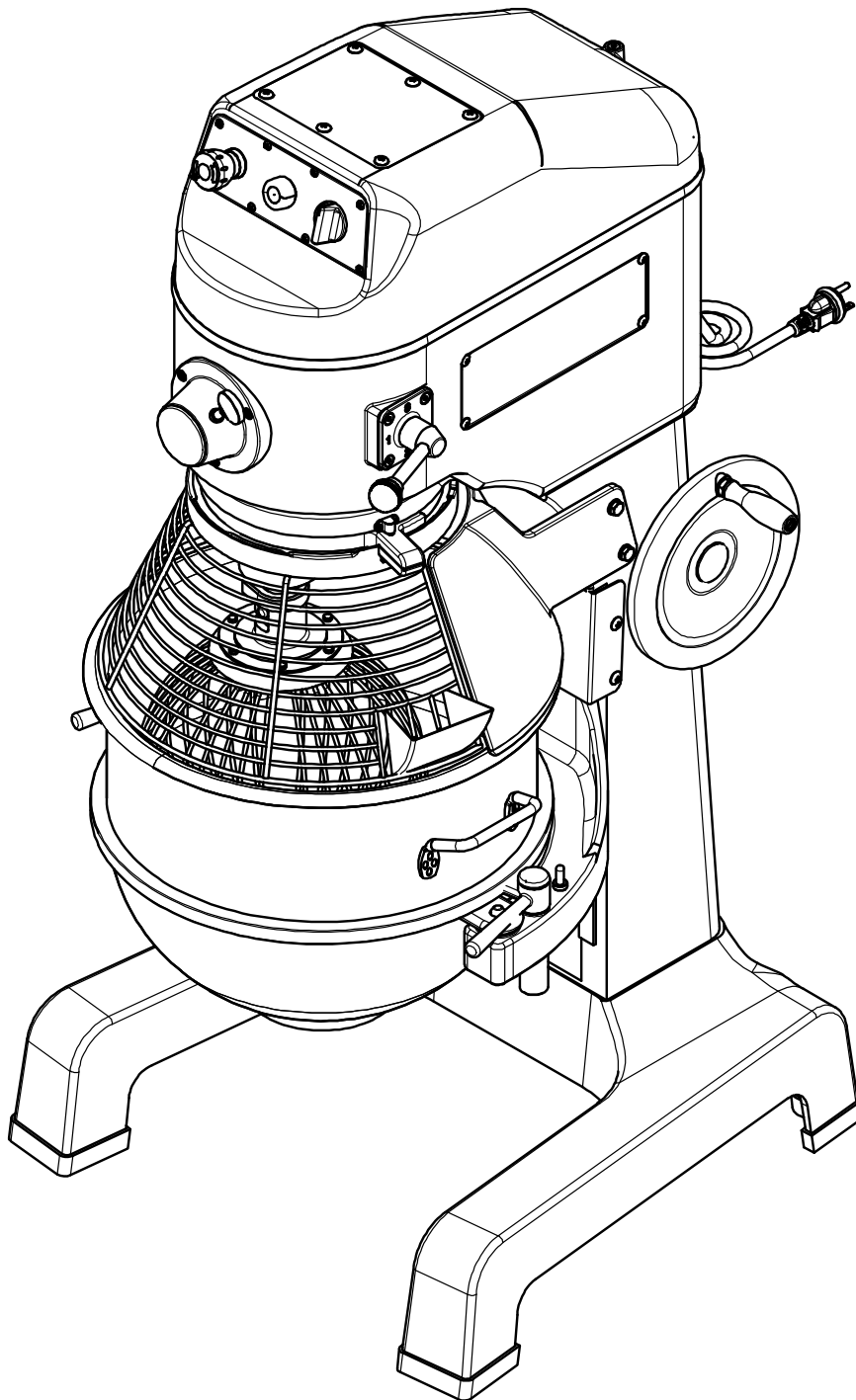

2016 Version

# SP-40HA & SP-40HI TOP COVER UNIT

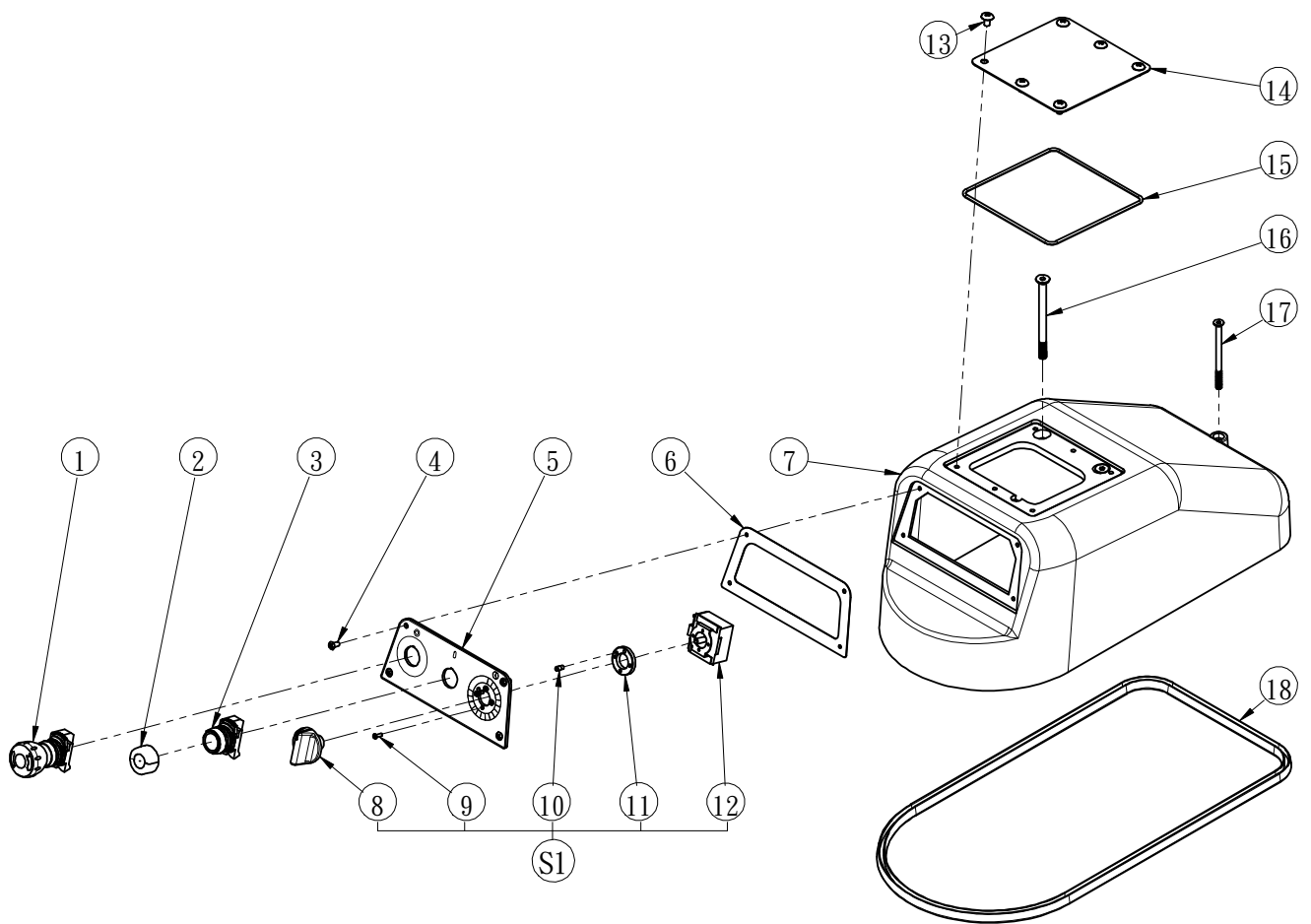

ITEM	PART NO.	Q'ty	REMARK
1	J101-001	1	
2	200517	1	
3	J201-001	1	WITH LIGHT
	J202-001	1	WITHOUT LIGHT
4	30515	4	
5	PL02-B56	1	WITH SPAR LOGO
6	40005-A	1	
7	40004	1	
S1	22008	1	ASSEMBLY PART
8	22008-2	1	
9	A104-A0605-A2/G1	4	
10	22008-3	1	
11	22008-1	1	
12	J301-001	1	
13	A106-A1105-D	6	
14	40002	1	
15	40003	1	
16	A108-A1331-C4	2	
17	A108-A1121-C4	1	
18	22004-2	1	PLEASE SPECIFY MODEL WHEN ORDERING

# SP-40HA & SP-40HI HEAD UNIT

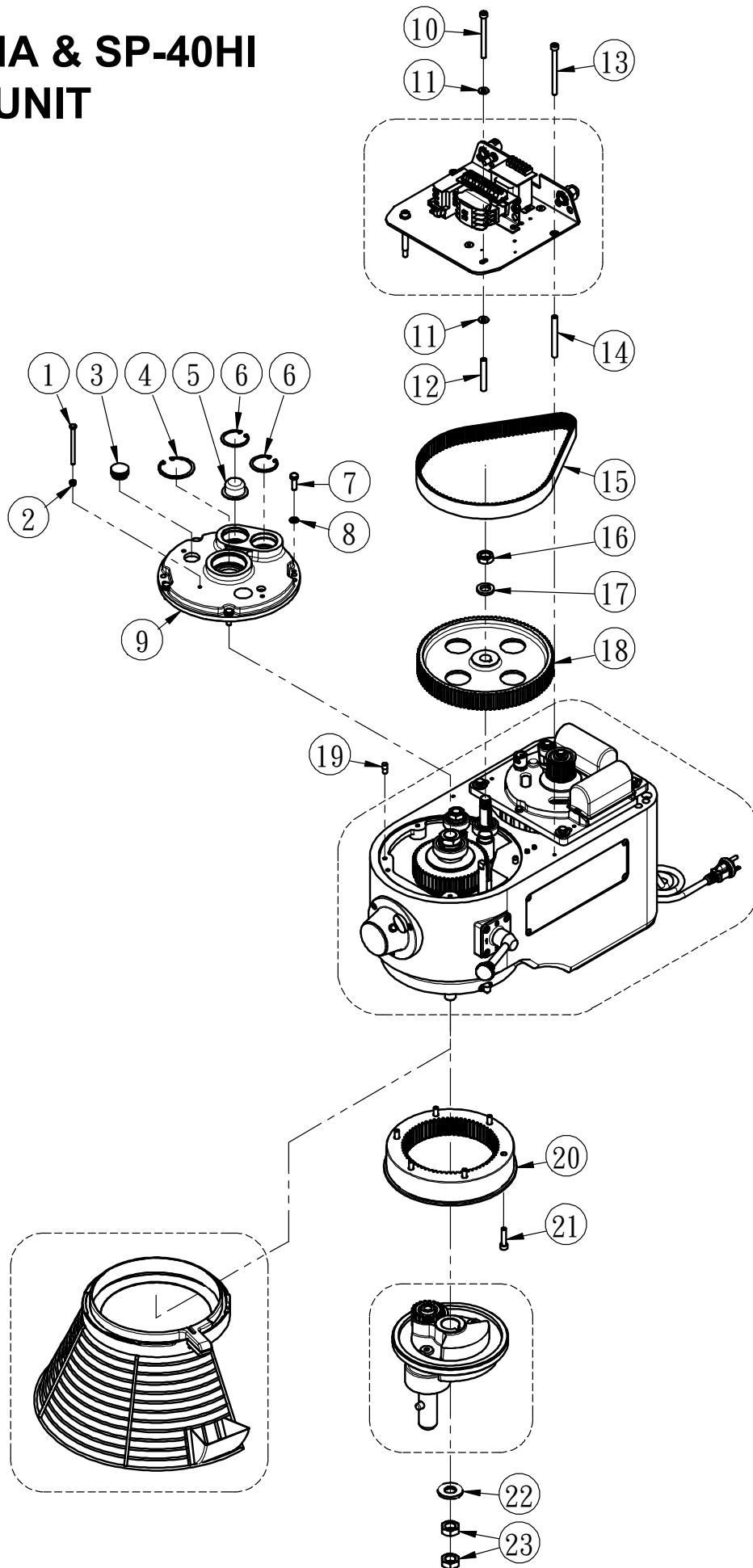

## SP-40HA & SP-40HI HEAD UNIT- PARTS TABLE

ITEM	PART NO.	Q'ty	REMARK
1	A101-A1120-A1	1	ATTACHMENT HUB USE
2	A201-A11-A1	1	ATTACHMENT HUB USE
3	T901-001	2	
4	RTW-62	1	
5	30079-1	1	
6	RTW-47	2	
7	A101-A1310-A1	4	
8	A302-A13-B4	4	
9	40077	1	
10	A102-A1321-C4	2	
11	A301-A13-18-1-A1	4	
12	30153	2	
13	A102-A1322-C4	2	
14	40085	2	
15	50072	1	50HZ USE
	60072	1	60HZ USE
16	A201-B33T100-A1	1	
17	A302-A19-B4	1	
18	40080	1	
19	30077-1	2	
20	40092	1	
21	A102-A1312-C4	6	
22	30130-1	1	
23	A201-B36T120-A1	2	

# SP-40HA & SP-40HI HEAD ASSEMBLY

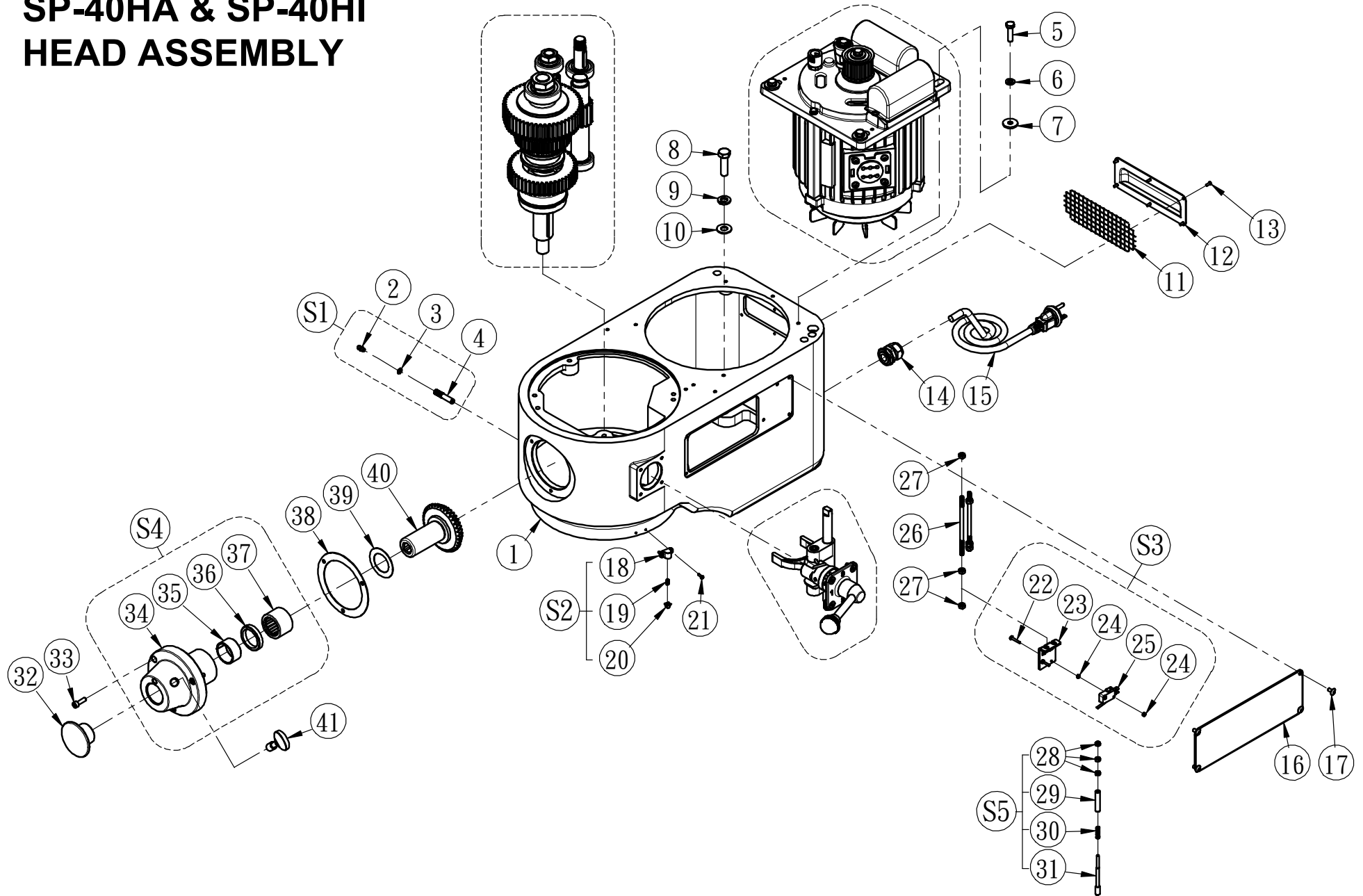

# SP-40HA & SP-40HI HEAD ASSEMBLY- PARTS TABLE

ITEM	PART NO.	Q'ty	REMARK
1	40087-2	1	SP-40HA USE ONLY; WITH ATTACHMENT HUB
	40087-3	1	SP-40A USE ONLY; WITHOUT ATTACHMENT HUB
	40087	1	SP-40HI USE ONLY; WITH ATTACHMENT HUB
	40087-1	1	SP-40I USE ONLY; WITHOUT ATTACHMENT HUB
S1	30165S	1	ASSEMBLY PART
2	200142	1	
3	200141	1	
4	30165	1	
5	A101-A1311-A1	4	
6	A302-A13-B4	4	
7	A301-A13-25-2-A1	4	
8	A101-A1713-A1	4	
9	A302-A17-B4	4	
10	A301-A17-25-1-A1	4	
11	40HI/76	1	
12	30076	1	
13	A701-32102	6	
14	T102-004	1	
15	-	1	PLEASE SPECIFY VOLTAGE WHEN ORDERING
16	PL01-B298	1	ENGLISH LANGUAGE
17	A106-A1005-D	4	
S2	200075	1	ASSEMBLY PART
18	-	1	
19	-	1	
20	-	1	
21	A106-A0604-D	2	
S3	200058S	1	ASSEMBLY PART
22	A105-A0609-A1	2	
23	200058	1	
24	A201-A06-A1	4	
25	J404-001	1	
26	40088	2	
27	A201-A11-A1	6	
S5	30096S	1	METAL ONE; ASSEMBLY PART
	30096-1S	1	PLASTIC ONE; ASSEMBLY PART
28	A201-A10-A1	3	INCLUDED WITH ASSEMBLY S5
29	22091-1	1	INCLUDED WITH ASSEMBLY S5
30	200044	1	INCLUDED WITH ASSEMBLY S5
31	30096	1	METAL ONE; INCLUDED WITH ASSEMBLY S5
	30096-1	1	PLASTIC ONE; INCLUDED WITH ASSEMBLY S5
32	22017	1	ATTACHMENT HUB USE ONLY
33	A102-A1109-C4	3	ATTACHMENT HUB USE ONLY
S4	40017S	1	ASSEMBLY PART; ATTACHMENT HUB USE ONLY
34	40017	1	
35	A501-035020	1	
36	TC-354508	1	
37	A503-TA3530	1	
38	40017-A	1	ATTACHMENT HUB USE ONLY
39	30014-A	1	ATTACHMENT HUB USE ONLY
40	40014	1	ATTACHMENT HUB USE ONLY
41	200005	1	ATTACHMENT HUB USE ONLY

# SP-40HA & SP-40HI GEAR BOX ASSEMBLY

## Master Shaft Assembly

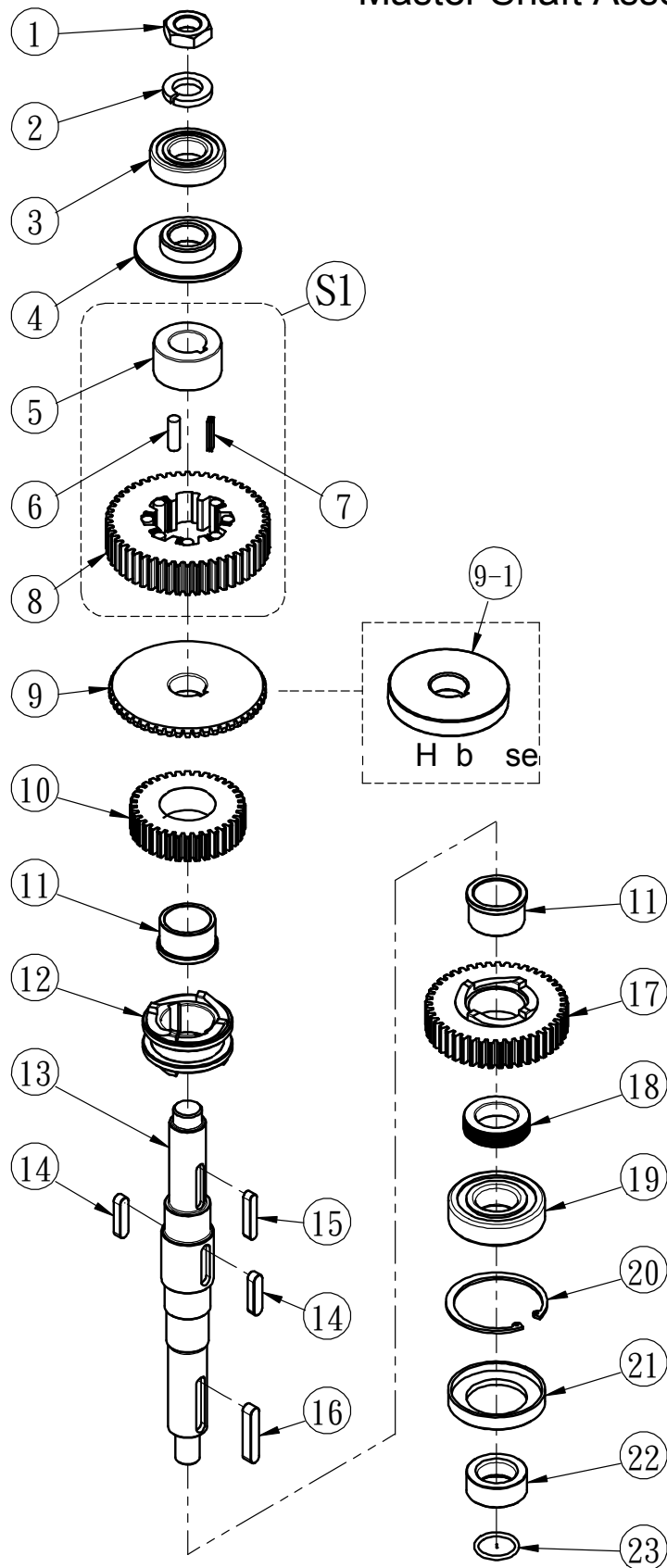

# SP-40HA & SP-40HI GEAR BOX ASSEMBLY PARTS TABLE

ITEM	PART NO.	Q'ty	REMARK
1	A201-B42T120-A1	1	
2	A302-A23-B4	1	
3	A502-6206LLU	1	
4	40113	1	
S1	40117S	1	ASSEMBLY PART
5	40114	1	
6	40115	8	
7	40116	8	
8	40117	1	
9	40118	1	ATTACHMENT HUB USE ONLY
9-1	30118-1	1	NO ATTACHMENT HUB USE ONLY
10	40120	1	
11	40123	2	
12	30133	1	
13	40130	1	
14	A402-100840	2	
15	A402-080845/G1	1	
16	A402-101055	1	
17	40122	1	
18	40124	1	
19	A502-6307LLU	1	
20	RTW-80	1	
21	TC-508013	1	
22	40127	1	
23	A601-P30	1	



# SP-40HA & SP-40HI GEAR BOX ASSEMBLY

## Transmission Shaft Assembly

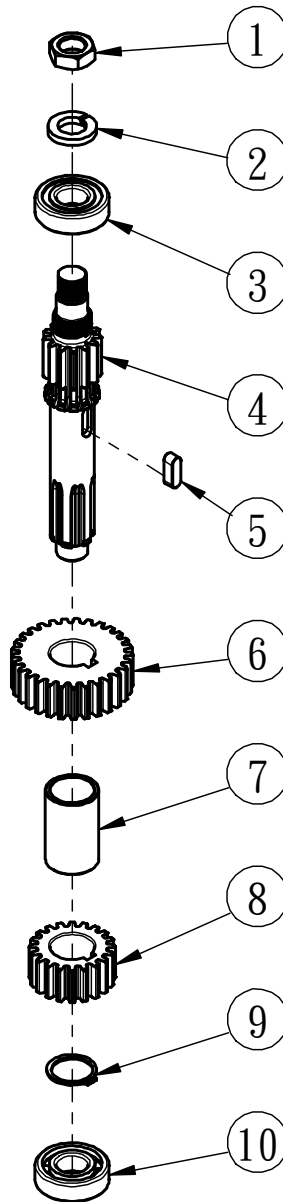

ITEM	PART NO.	Q'ty	REMARK
1	A201-B33T100-A1	1	
2	A302-A20-B4	1	
3	A502-6204LLU	1	
4	40150	1	
5	A402-080823	1	
6	40148	1	
7	40144	1	
8	40143	1	
9	STW-28	1	
10	A502-6204	1	

# SP-40HA & SP-40HI GEAR BOX ASSEMBLY

## Drive Shaft Assembly

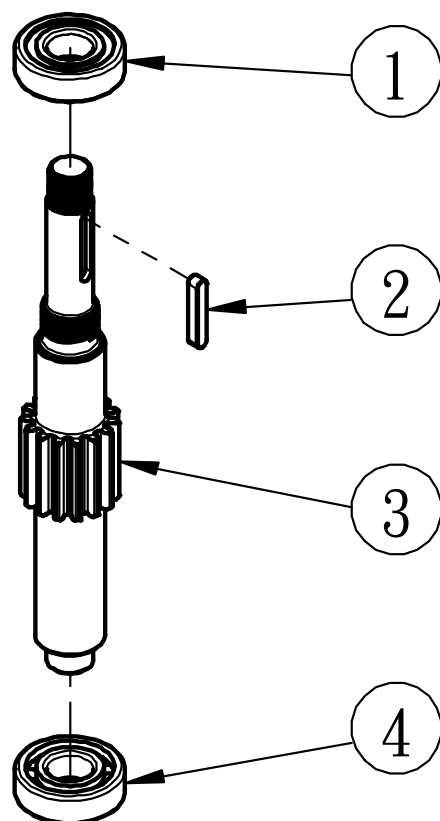

ITEM	PART NO.	Q'ty	REMARK
1	A502-6204LLU	1	
2	A402-060635	1	
3	40145	1	
4	A502-6204	1	

# SP-40HA & SP-40HI SPEED HANDLE & YOKE-SHIFTER ASSEMBLY

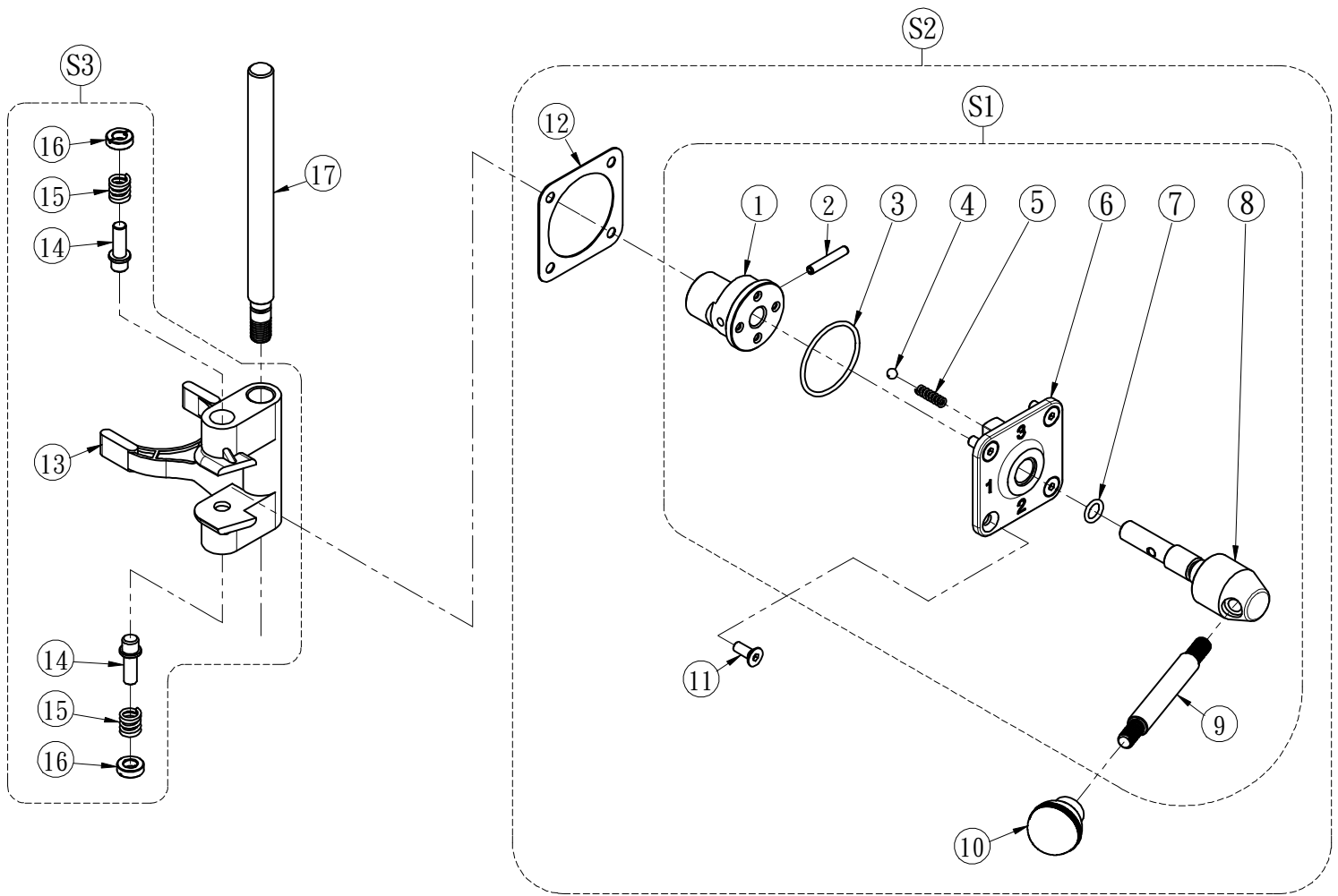

ITEM	PART NO.	Q'ty	REMARK
S1	40060S	1	
1	-	1	
2	-	1	
3	-	1	
4	-	2	
5	-	2	ASSEMBLY PART; INCLUDE #1~#9
6	-	1	
7	-	1	
8	-	1	
9	30057	1	
10	U101-003	1	
11	A108-A1108-C2	4	ASSEMBLY PART; INCLUDES1, #10, #11 AND #12
12	30059-A	1	
S2	30059-AS-1	1	
S3	30139S	1	
13	-	1	
14	-	2	ASSEMBLY PART
15	-	2	
16	-	2	
17	40135	1	

# SP-40HA & SP-40HI MOTOR ASSEMBLY

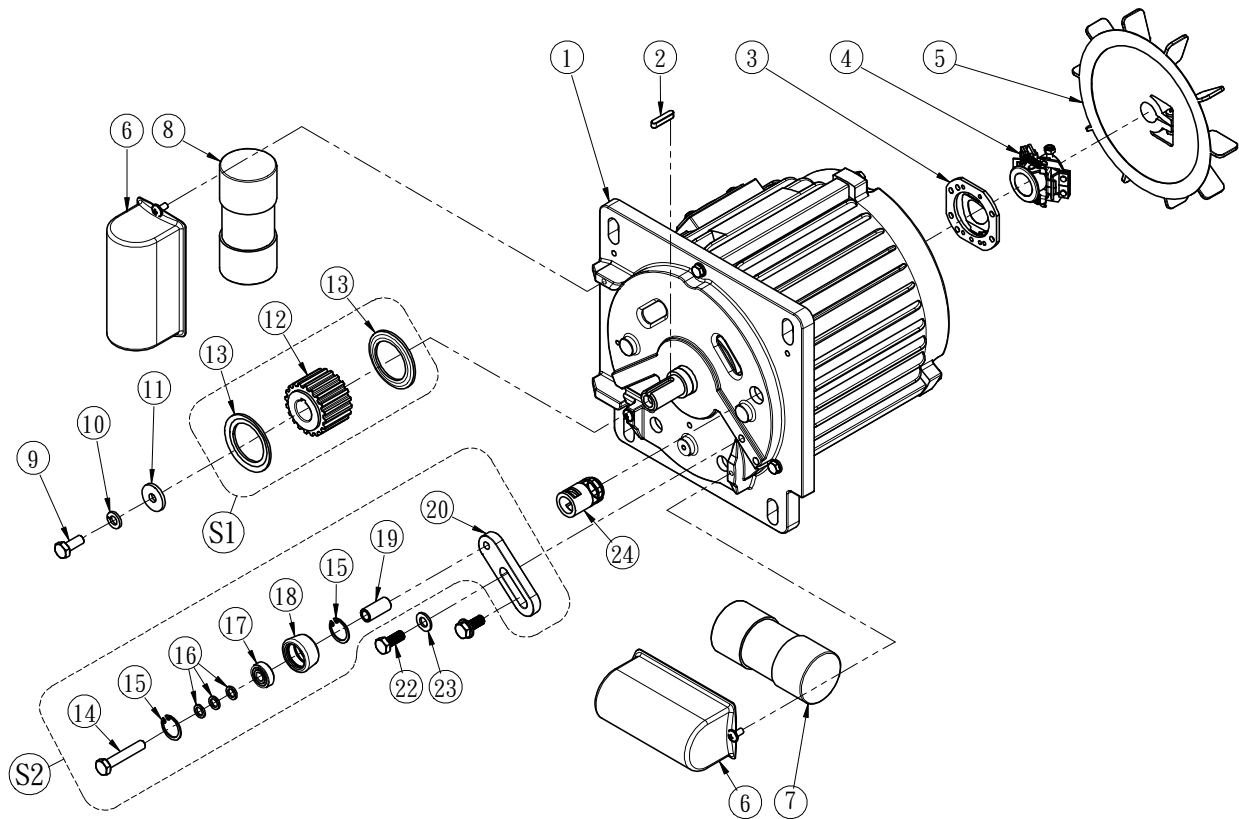

ITEM	PART NO.	Q'ty	REMARK
1	40068	1	PLEASE SPECIFY VOLTAGE WHEN ORDERING
2	A402-050525	1	
3	J701-001	1	SINGLE PHASE USE ONLY; PLEASE SPECIFY VOLTAGE WHEN ORDERING
4	J802-19-50	1	50HZ SINGLE PHASE USE ONLY; PLEASE SPECIFY VOLTAGE WHEN ORDERING
	J802-19-60	1	60HZ SINGLE PHASE USE ONLY; PLEASE SPECIFY VOLTAGE WHEN ORDERING
5	T801-19-185-10	1	
6	-	2	PART FROM MOTOR SUPPLIER
7	K201-400/250	1	SINGLE PHASE USE ONLY; PLEASE SPECIFY VOLTAGE WHEN ORDERING
8	K202-40/300	1	SINGLE PHASE USE ONLY; PLEASE SPECIFY VOLTAGE WHEN ORDERING
9	A101-A1309-A1	1	
10	A302-A13-B4	1	
11	A301-A13-25-2-A1	1	
S1	30071S	1	60HZ; ASEEMBLY PART
	30071-1S	1	50HZ; ASEEMBLY PART
12	-	1	
13	-	2	
S2	30158-1S	1	ASEEMBLY PART
14	-	1	
15	-	2	
16	-	3	
17	-	1	
18	-	1	
19	-	1	
20	-	1	
21	-	-	
22	A101-A1309-A1	2	
23	A301-A13-16-2-D	2	
24	T101-002	1	

# SP-40HA & SP-40HI PLANETARY UNIT

ITEM	PART NO.	Q'ty	REMARK
1	A201-B29T080-A1	1	
2	A301-A19-30-1-A1	1	
3	40021	1	
4	A502-6205ZZ	1	
5	40023	1	
6	A502-6206ZZ	1	
7	TC-406212	1	
8	A402-070723	1	
S1	40027S	1	ASSEMBLY PART
9	-	1	
10	30028	1	
11	A301-A13-18-1-A1	2	
12	A101-A1306-A1	2	
13	A301-A15-20-1-A1	2	
14	A101-A1508-A1	2	

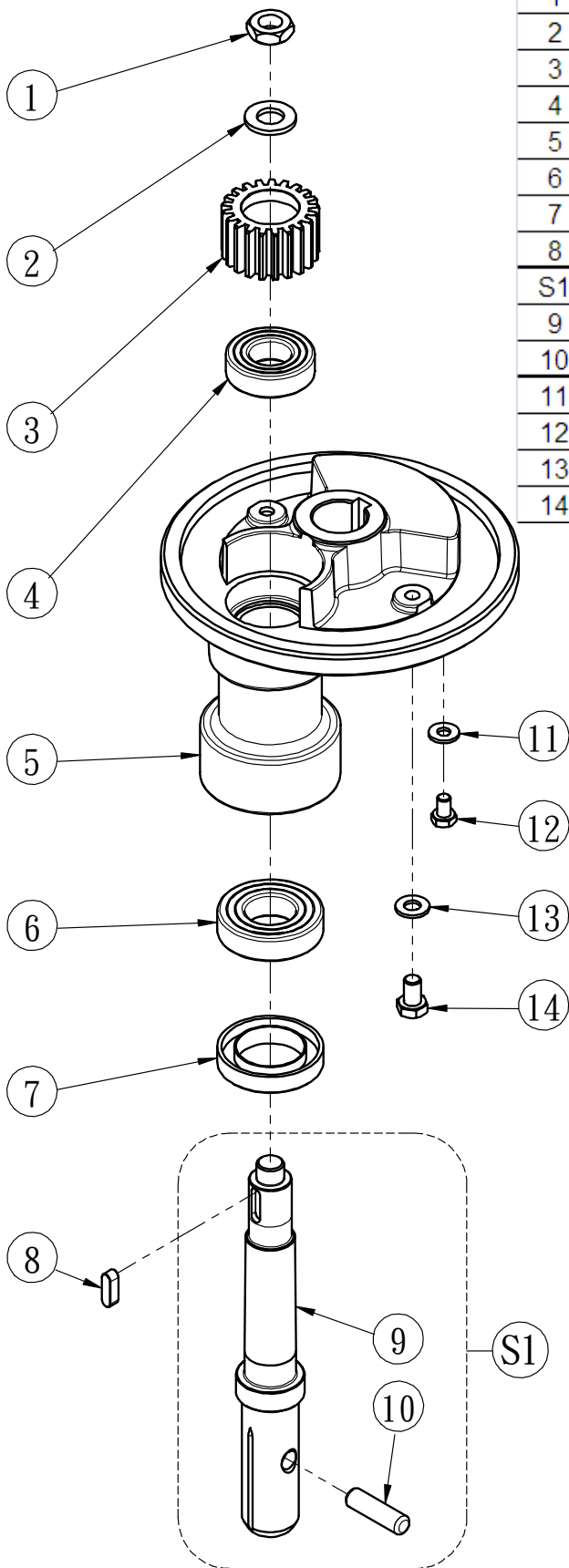

# SP-40HA REMOVBLE SAFETY GUARD UNIT

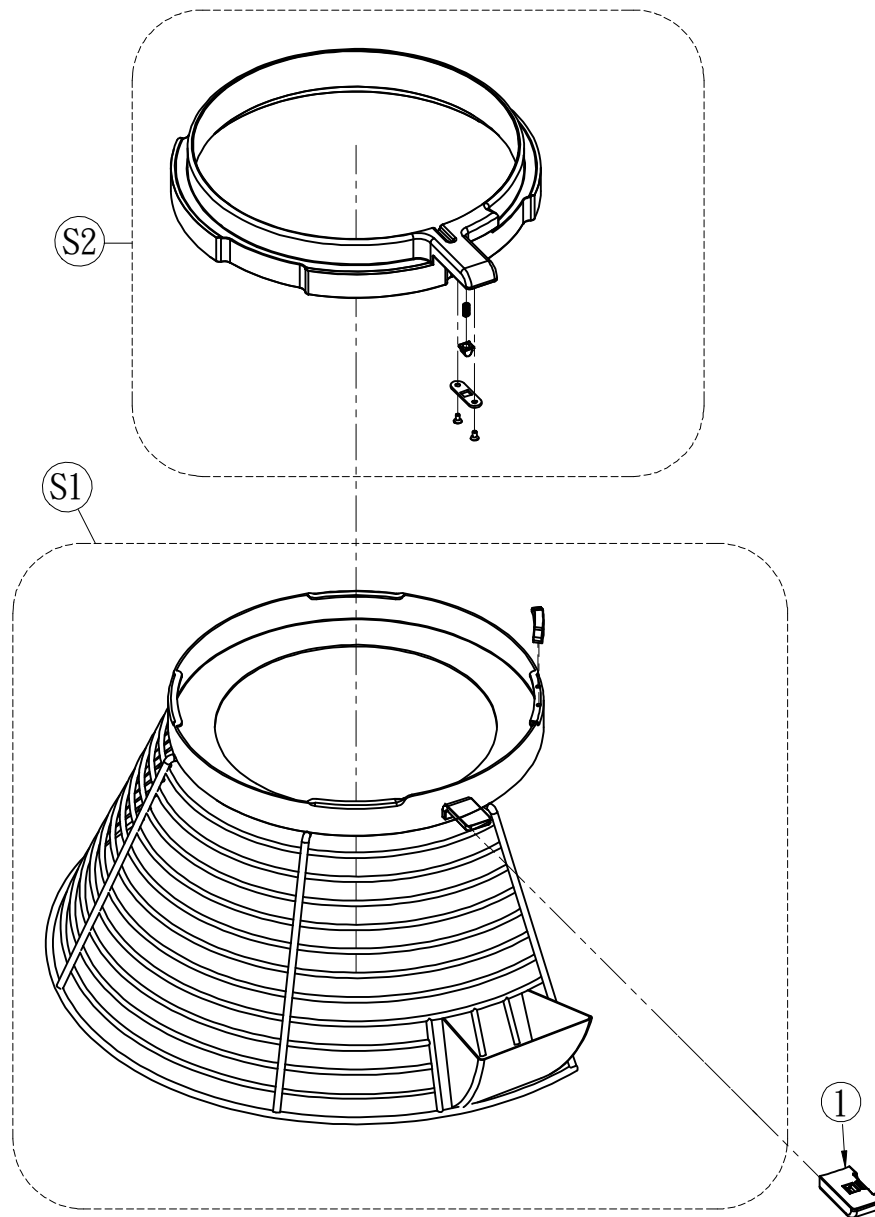

ITEM	PART NO.	Q'ty	REMARK
S1	40508S	1	ASSEMBLY PART
1	40504-A	1	
S2	40090-4S	1	ASSEMBLY PART

# SP-40HI SAFETY GUARD UNIT- FIXED TYPE

## METAL SLIDE SHEATH

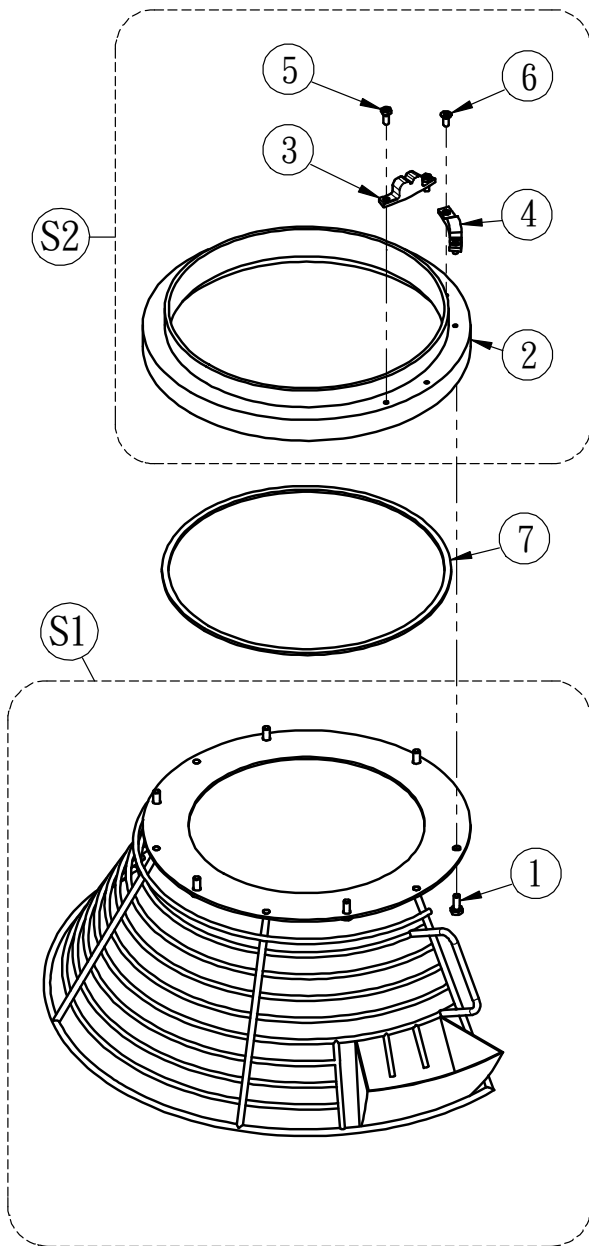

## PLASTIC SLIDE SHEATH

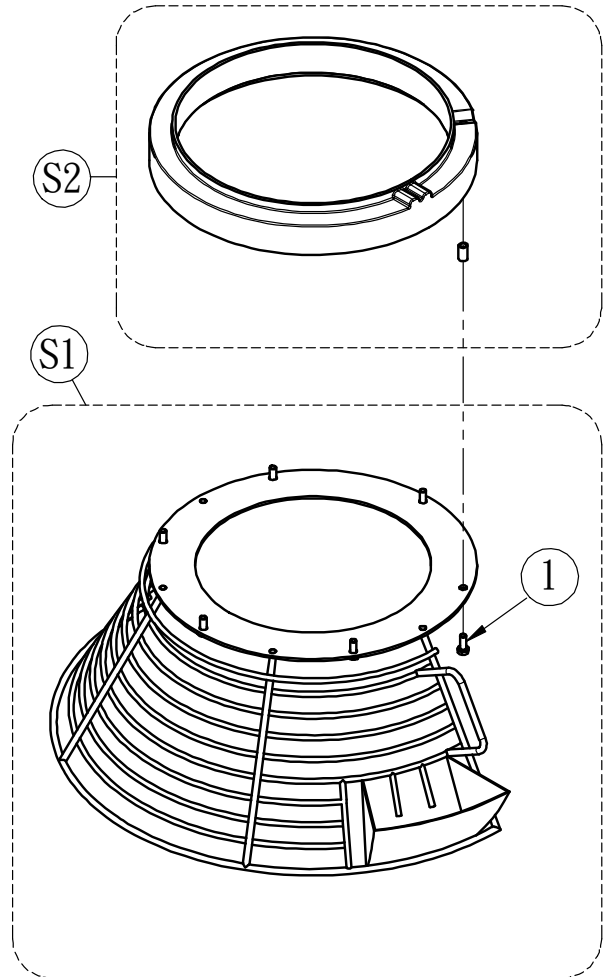

ITEM	PART NO.	Q'ty	REMARK
S1	40094S	1	ASSEMBLY PART
1	A101-A1006-D	6	
S2	40090-2S	1	METAL ONE; ASSEMBLY PART
	40090-1S		PLASTIC ONE; ASSEMBLY PART
2	-	1	
3	30161	1	
4	200041	1	
5	A110-A0808-D	2	
6	A107-A0805-D	2	
7	40091	1	METAL SLIDE SHEATH USE ONLY

# SP-40HA & SP-40HI ELECTRONIC PART ASSEMBLY

ETL SPEC.

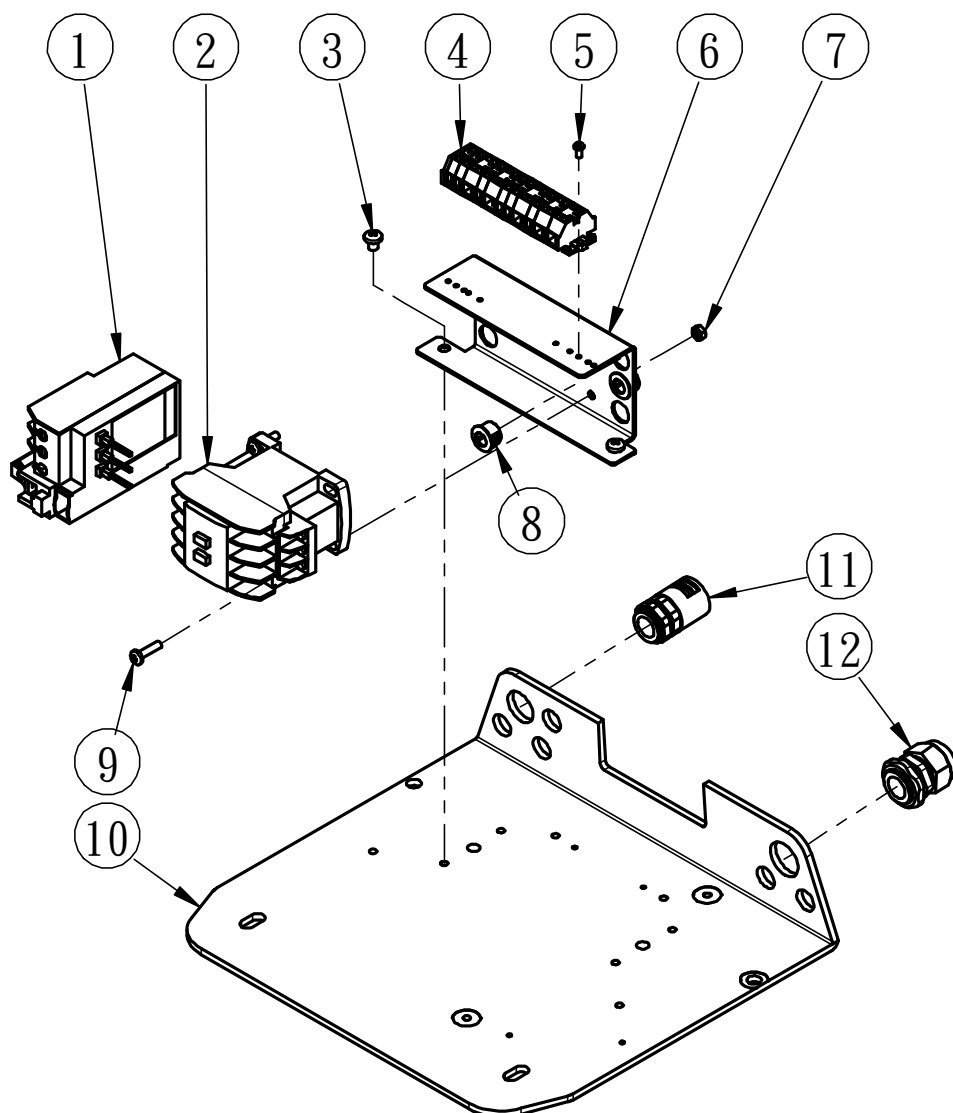

ITEM	PART NO.	Q'ty	REMARK
1	40HI/154	1	SPECIFICATION IS DIFFERENT SUBJECT TO ELT AND CE SPEC. PLEASE SPECIFY VOLTAGE WHEN ORDERING
2	40HI/11	1	SPECIFICATION IS DIFFERENT SUBJECT TO ELT AND CE SPEC. PLEASE SPECIFY VOLTAGE WHEN ORDERING
3	A105-A1003-A1	2	
4	40HI/12	1	
5	A105-A0603-A1	2	
6	30013-A	1	
7	A201-A08-A1	2	
8	T601-001	2	
9	A105-A0808-A1	2	
10	40013	1	
11	T101-002	1	
12	T102-002	1	



# SP-40HA & SP-40HI ELECTRONIC PART ASSEMBLY

CE SPEC.

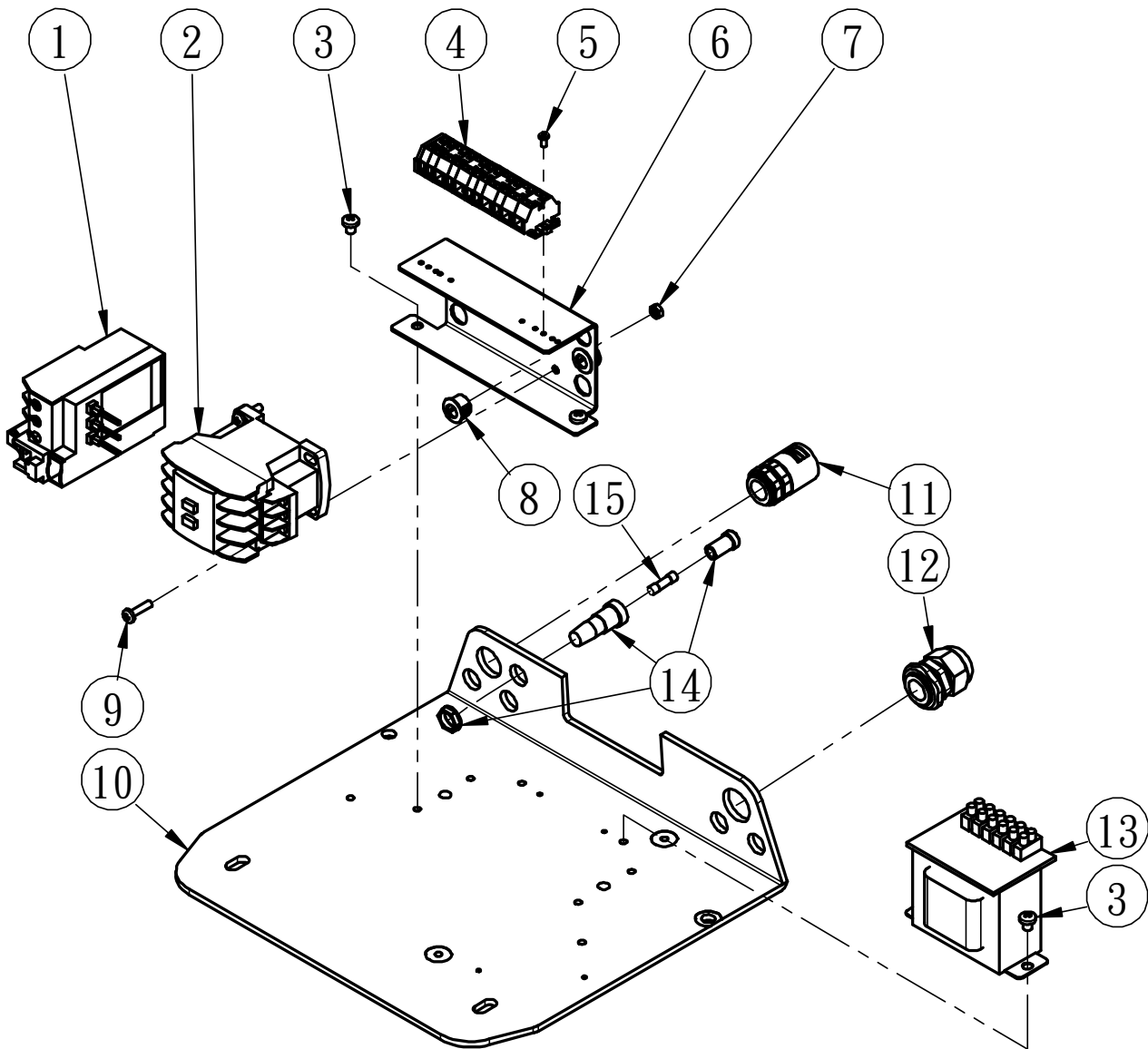

ITEM	PART NO.	Q'ty	REMARK
1	40HI/154	1	SPECIFICATION IS DIFFERENT SUBJECT TO ELT AND CE SPEC. PLEASE SPECIFY VOLTAGE WHEN ORDERING
2	40HI/11	1	SPECIFICATION IS DIFFERENT SUBJECT TO ELT AND CE SPEC. PLEASE SPECIFY VOLTAGE WHEN ORDERING
3	A105-A1003-A1	4	
4	40HI/12	1	
5	A105-A0603-A1	2	
6	30013-A	1	
7	A201-A08-A1	2	
8	T601-001	2	
9	A105-A0808-A1	2	
10	40013	1	
11	T101-002	1	
12	T102-002	1	
13	40HI/157	1	PLEASE SPECIFY VOLTAGE WHEN ORDERING
14	L302-6.3-250	1	
15	L301-A-1-250	1	

# SP-40HA & SP-40HI BODY AND BASE UNIT

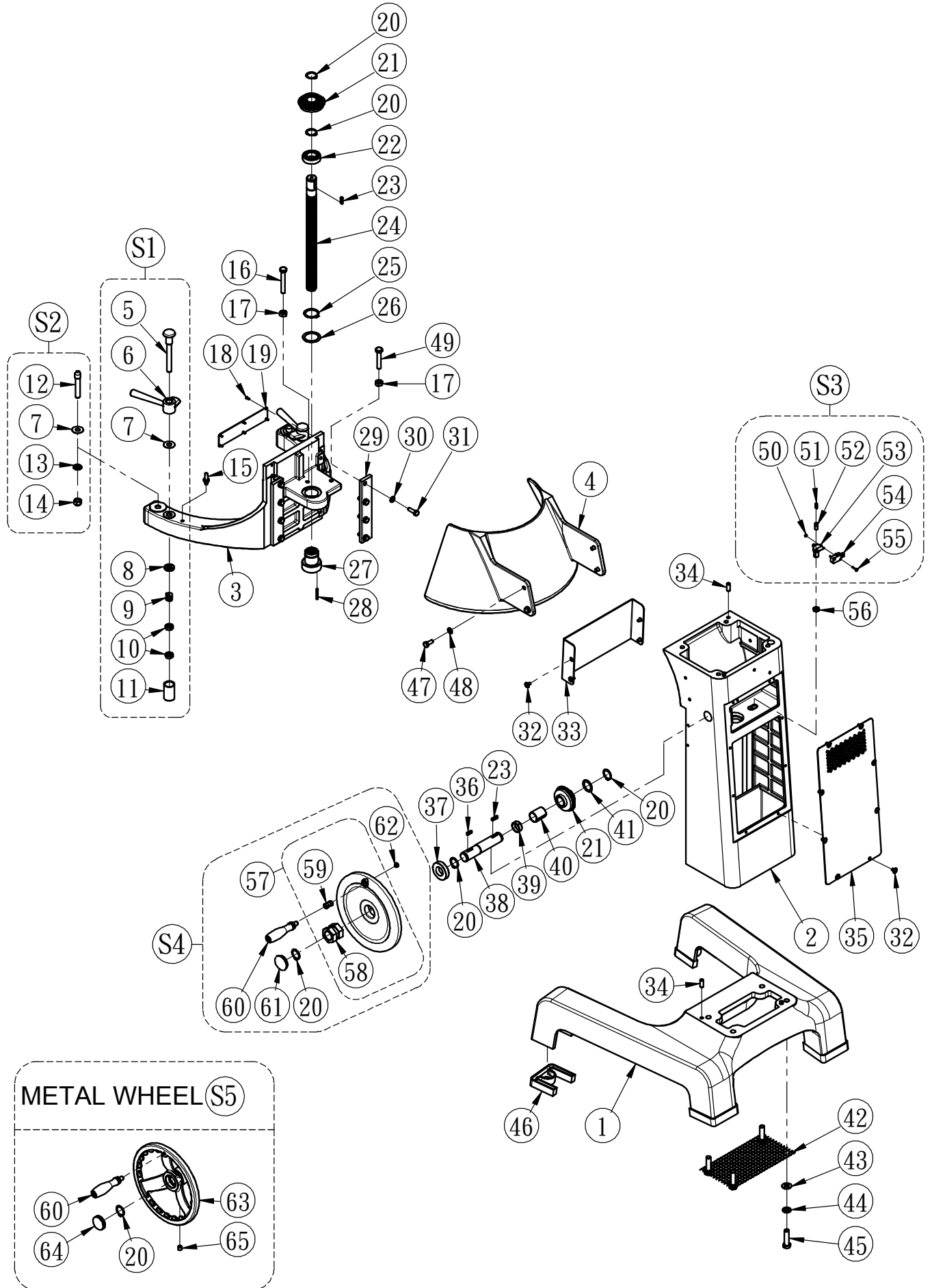

# SP-40HA & SP-40HI BODY AND BASE UNIT PARTS TABLE

ITEM	PART NO.	Q'ty	REMARK
1	40038	1	
2	40042	1	
3	40034	1	
4	40036	1	
	40036-1	1	
S1	30033S	2	ASSEMBLY PART
5	30108	2	
6	30033	2	
7	A301-A17-30-1-D	4	
8	30108-1	2	
9	30108-2	2	
10	A201-A17T070-A1	4	
11	C-8057	2	
S2	40109S	2	ASSEMBLY PART
12	40109	2	
13	A302-A17-A1	2	
14	A204-A17-A1	2	
15	30109-1	2	
16	A101-A1519-A1	1	
17	A201-A15-A1	2	
18	A701-32089	6	
19	40102-1	1	
20	STW-25	5	
21	30045	2	
22	A502-6005LLU-1	1	
23	A402-050520	2	
24	30041	1	
25	STW-35	1	
26	30104-A	1	
27	30104	1	
28	A902-04032	2	
29	40035	2	
30	A302-A13-B4	8	
31	A101-A1310-A1	8	
32	A106-A1105-D	12	
33	40102	1	
34	A901-08023	4	
35	40055	1	

# SP-40HA & SP-40HI BODY AND BASE UNIT PARTS TABLE

ITEM	PART NO.	Q'ty	REMARK
36	A402-050517	1	
37	40053-1	1	
38	40047	1	
39	A501-025010	1	
40	A501-025035	1	
41	30045-A	1~2	PLEASE CONSULT US WHEN ORDERING
	30045-B		
42	40037	1	
43	A301-A17-25-1-A1	4	
44	A302-A17-B4	4	
45	A101-A1714-A1	4	
46	40162	1	
47	A101-A1309-D	4	
48	A301-A13-16-2-D	4	
49	A101-A1516-A1	1	
S3	30051-1S	1	ASSEMBLY PART
50	A201-A06-A1	2	
51	200075-1	1	
52	30051-1	1	
53	30051	2	
54	J403-001	1	
55	A105-A0630-A1	2	
56	A201-B58T050-E2/G1	1	
S4	30053-2S	1	PLASTIC WHEEL; ASSEMBLY PART
57	-	1	
58	-	1	
59	-	1	
60	B101-001	1	
61	30053-2	1	
62	T501-HP08	1	
S5	40053S	1	METAL WHEEL; ASSEMBLY PART
63	40053	1	
64	40053-2	1	
65	A103-A1505-C4	1	

# SP-40HA & SP-40HI ACCESSORY LIST

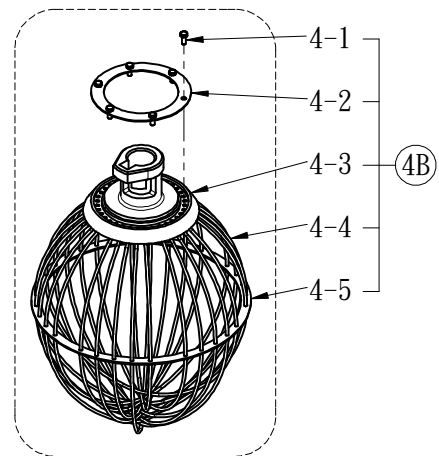
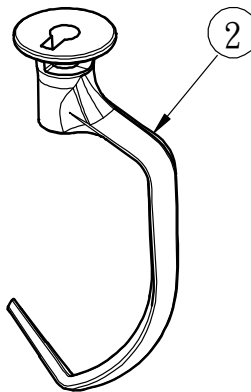
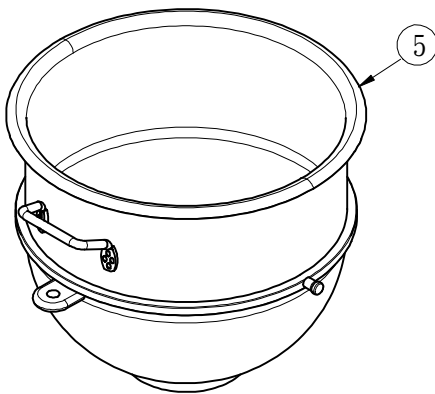
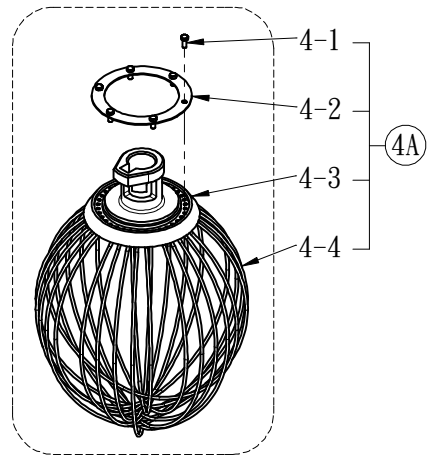
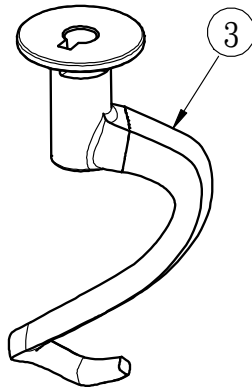
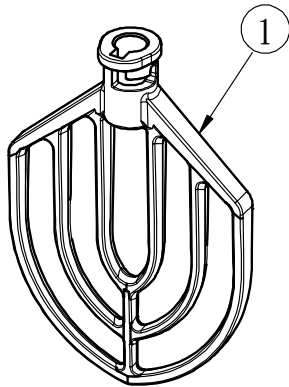

ITEM	PART NO.	DESCRIPTION	Q'ty	REMARK
1	40030	ALUMINUM FLAT BEATER	1	STANDARD ACCESSORY
	40030-1	STAINLESS STEEL FLAT BEATER	1	OPTIONAL ACCESSORY
2	40029-3	ALUMINUM DOUGH HOOK- J TYPE	1	OPTIONAL ACCESSORY
3	40029-2	ALUMINUM DOUGH HOOK- SPIRAL TYPE	1	STANDARD ACCESSORY
4A	40031S	WHIP	1	STANDARD ACCESSORY- ASSEMBLY PART
4B	40031-2S	HEAVY DUTY WHIP	1	OPTIONAL ACCESSORY- ASSEMBLY PART
4-1	A101-A1006-D	SCREW(M5x12L)	6	
4-2	30031-1	RING COVER	1	
4-3	-		1	
4-4	-		15	
4-5	-		1	
5	40032	BOWL	1	STANDARD ACCESSORY

# SP-40HA & SP-40HI 20QT REDUCITON KIT OPTION ACCESSORY

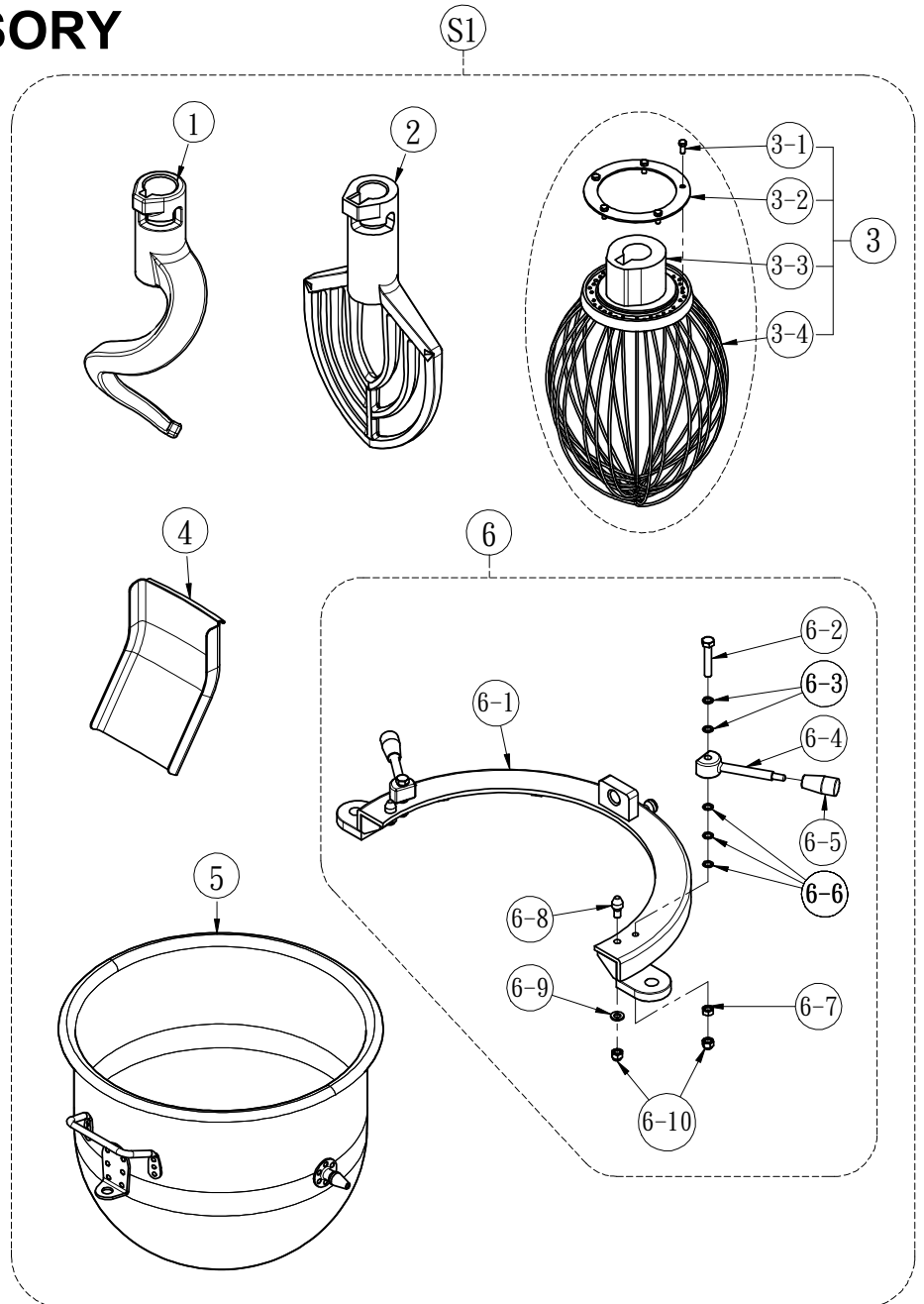

ITEM	PART NO.	DESCRIPTION	Q'ty	REMARK
S1	20/40ACC	20QT REDUCTION KIT	1	INCLUDE BOWL, TOOLS AND ADAPTER
1	40029-L	20QT ALUMINUM SPIRAL DOUGH HOOK	1	
2	40030-L	20QT ALUMINUM FLAT BEATER	1	
3	40031-LS	20QT WHIP	1	
3-1	A101-A1006-D	SCREW(M5x12L)	5	ASSEMBLY PART
3-2	200018-E	RING COVER	1	
3-3	-		1	
3-4	-		15	
4	40094-1	CHUTE FOR SAFETY GUARD	1	
5	40032-L	20QT BOWL	1	
6	20/40RACK	ADAPTER ASSEMBLY	1	
6-1	-	ADAPTER	1	
6-2	A101-A1314-D	SCREW(M8x45L)	2	ASSEMBLY PART
6-3	A301-A13-12-2-A1	WASHER(M8x12x1.5t)	4	
6-4	RC033	BOWL CLAMP HANDLE	2	
6-5	RC033-1	KNOB	2	
6-6	A301-A13-12-1-A1	WAHER(M8x12x1t)	6	
6-7	A201-A13-D	NUT(M8)	2	
6-8	40109L	DOWEL PIN	2	
6-9	A302-A13-D	SPRING WAHSER	2	
6-10	A204-A13-D	NUT(L-M8)	4	

# SP-40HA & SP-40HI BOWL SCRAPER OPTION ACCESSORY

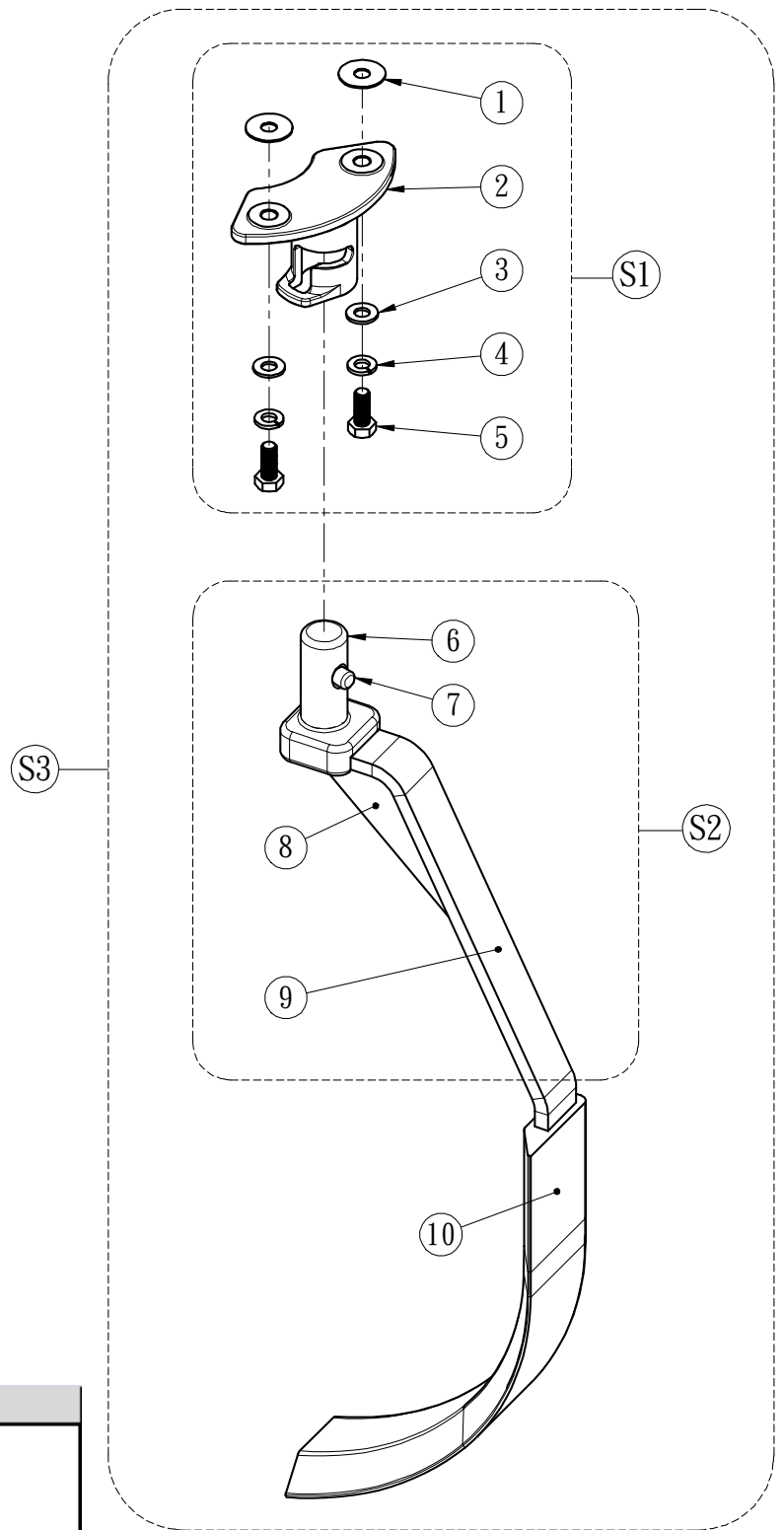

ITEM	PART NO.	Q'ty	REMARK
S1	40511S	1	ASSEMBLY PART
1	40512	2	
2	40511	1	
3	A301-A13-22-1-D	2	
4	A302-A13-D	2	
5	A101-A1310-D	2	
S2	40509S	1	ASSEMBLY PART
6	-	1	
7	-	1	
8	-	1	
9	-	1	
10	40515	1	
S3	40/SCRP	1	INCLUDE #10, S1 AND S2 AS ONE SET

# SP-40HA & SP-40HI BOWL TRUCK OPTION ACCESSORY

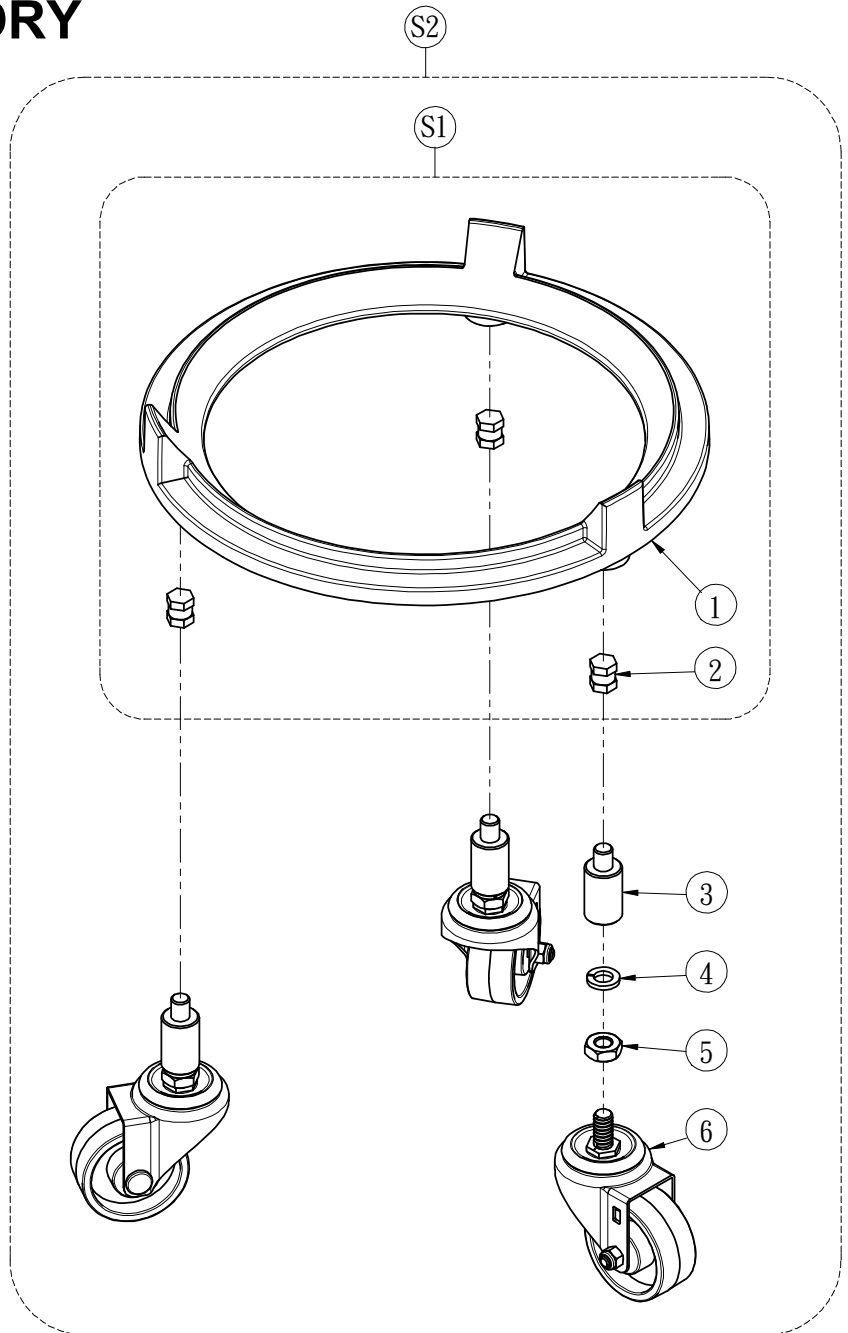

ITEM	PART NO.	Q'ty	REMARK
S1	60032-TS	1	ASSEMBLY PART
1	-	1	
2	-	3	
3	40032-T	3	
4	A302-C06-A1	3	
5	A201-C06-A1	3	
6	T301-001	3	
S2	TROLLY/40	1	INCLUDE S1, #3, #4, #5 AND #6 AS ONE SET