



No.145, 11th Industry Rd. Ta-Li City,
Taichung Hsien 412 Taiwan
Phone:886-4-2491-7585
E-Mail:spar@tcts.seed.net.tw

SP-50HA Mixer

Project _____ Item # _____ Quantity _____



SP-50HA Mixer

Model
SP-50HA 50 Quart Mixer



Built into each mixer is the quality of workmanship and design synonymous with SPAR.

Standard Features



- Powerful 2 HP custom built motor
- Three fixed speeds
- High torque transmission
- Heat-treated hardened steel alloy gears and shafts
- Permanently lubricated transmission
- Thermal overload protection
- Rigid cast iron body
- Stainless steel bowl guard with built in ingredient chute
- NSF approved enamel gray paint (optional)
- Front mounted controls
- 15 minute timer
- Industry standard #12 attachment hub
- Safety interlocked bowl guard and bowl lift
- Non-slip rubber feet
- 6 foot cord and ground plug (single phase only)

Standard Accessories



- 50 quart stainless steel bowl
- Flat beater (aluminum)
- Stainless steel wire whip
- Spiral dough hook (aluminum)

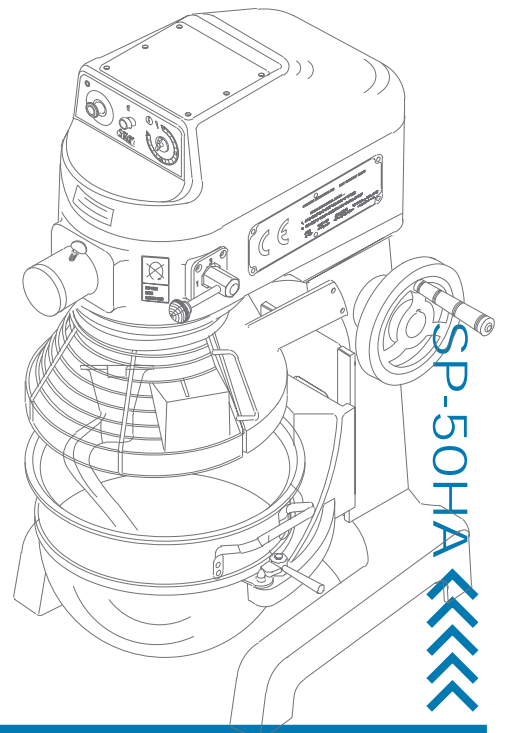



No.145, 11th Industry Rd. Ta-Li City,
Taichung Hsien 412 Taiwan
Phone:886-4-2491-7585
E-Mail:spar@tcts.seed.net.tw

SP-50HA Mixer

Specifications

● **Motor** <<<<<<
2 HP (1500W), grease packed ball bearing, air-cooled,
230V/50Hz/1Ph, 220V/380V/3Ph

● **Controls** <<<<<<
Spar Mixer controls are front-mounted to give easy access in cramped kitchen environments. The following controls are standard on all Spar Mixers: separate start and emergency stop buttons so operators can shut down the mixer immediately in an emergency situation, a 15-minute timer which shuts off the machine after set time has elapsed, and thermal overload protection

● **Cord and Plug** <<<<<<
Both single phase and three phase are hard wired

● **Transmission** <<<<<<
Heat-treated, hardened alloy, precision milled gears operate with planetary action. Gears are packed in a long-lasting, high pressure grease. Planetary gears are driven by an oversized cog-wheel, which is in turn driven by a cogged belt powered by the motor drive shaft. Cogged belt is a long-lasting, rugged fibre/rubber composite. This unique design yields high-torque mixing power while avoiding the high cost encountered repairing direct-drive transmission components.

● **Speeds** <<<<<<

Speed	Agitator rpm	Hub rpm's
Low Speed	99	41
Intermediate Speed	176	73
High Speed	320	133

● **Bowls and Agitators** <<<<<<
Standard equipment includes a 50Qt. (50L) high quality stainless steel bowl, dough hook, flat beater, and whip. A sturdy hand lever on the body column raises and lowers the bowl as well as locking in place at the top and bottom positions.

● **Attachments** <<<<<<
 Vegetable Slicer for #12 hub
 Meat grinder for #12 hub
 20 quart adapter kit

● **Finish** <<<<<<
Top (transmission cover): metallic bronze epoxy enamel
Bottom:metallic gray epoxy enamel

● **Shipping Information** <<<<<<
N.W. 270kgs
G.W. 310kgs

Carton Size:
Depth x Width x Height
75cm x 65cm x 131cm

Cartons are affixed to an undersized skid (pallet), the weight and diminsions of this skid are not included above and may vary from shipment to shipment.

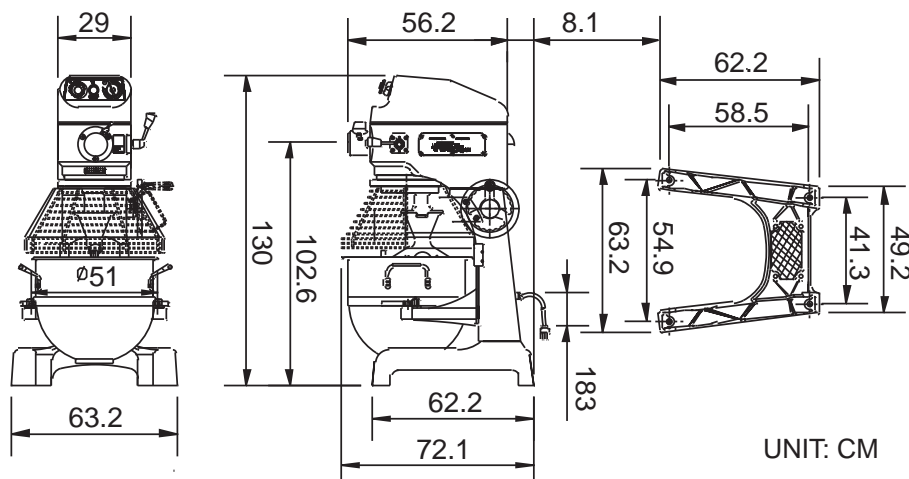

UNIT: CM

SP-50HA <<<<<<



◆ HI Series

MODEL	Capacity	Hores Power	Voltage 60HZ/50HZ	Weight (N. W.)	L x W x H (cm)	3-Speeds R.P.M	Extra Accessories	Mincer	Veget
SP-500A SP-502A	5 quarts	750W	110V/220V	15KGS	40 x 31 x 45.5	40~260			
SP-800A	8 quarts	1/4 HP	110V/220V	25KGS	47 x 28 x 58	132.234.421			
SP-100A	10 quarts	1/3 HP	110V/220V	65KGS	46 x 45 x 76	106.196.358		VH-12	V99S
SP-200A	20 quarts	1/2 HP	110V/220V	80KGS	53 x 52 x 87	106.196.358	10 QT	VH-12	V99S
SP-22HA	24 quarts	3/4 HP	110V/220V	110KGS	56 x 55 x 91	108.183.352	10 QT	VH-12	V99S
SP-30HA	30 quarts	1.0 HP	220V/380V	180KGS	67 x 55 x 117	99.176.320	20 QT	VH-12	V99S
SP-34HA	40 quarts	1.25 HP	220V/380V	190KGS	67 x 55 x 117	99.176.320	20 QT	VH-12	V99S
SP-40HA	40 quarts	1.5 HP	220V/380V	250KGS	75 x 65 x 131	99.176.320	20 QT	VH-12	V99S
SP-50HA	50 quarts	2.0 HP	220V/380V	270KGS	75 x 65 x 131	99.176.320	20 QT	VH-12	V99S
SP-60HA	60 quarts	3 HP	220V/380V	270KGS	78 x 65 x 131	99.176.320	30 QT	VH-12	V99S
SP-B80HI	80 quarts	3 HP	220V/380V/415V 50/60HZ 3PH	455KGS	108 x 79 x 156	69.121.204.356	40 QT	VH-12	V99S

Spar Food Machinery Mfg. CO., Ltd.

No.145, 11th Industry Rd. Ta-Li City, Taichung Hsien 412 Taiwan

TEL : 886-4-2491-7585

FAX : 886-4-2491-7565

E-MAIL : spar@tcts.seed.net.tw

http://www.sparmixers.com