



No.145, 11th Industry Rd. Ta-Li City,  
Taichung Hsien 412 Taiwan  
Phone:886-4-2491-7585  
E-Mail:spar@tcts.seed.net.tw

# SP-800A Mixer

Project \_\_\_\_\_ Item # \_\_\_\_\_ Quantity \_\_\_\_\_



Model  
SP-800A 8 Quart Mixer



## Standard Features



- Gear driven, high torque transmission
- Three fixed speeds
- 1/4 HP custom built motor
- Heat-treated hardened steel alloy gears and shafts
- Permanently lubricated transmission
- Thermal overload protection
- Rigid cast aluminum body
- Polycarbonate bowl guard
- Safety interlocked bowl lift
- Front mounted controls
- 15 minute digital timer
- 6 foot cord and plug

## Standard Accessories



- 8 quart stainless steel bowl
- Flat beater (aluminum)
- Stainless steel wire whip
- Spiral dough hook (aluminum)

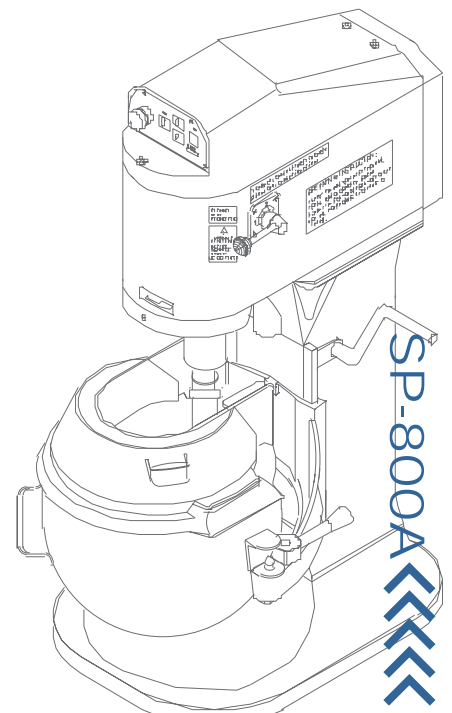



No.145, 11th Industry Rd. Ta-Li City,  
Taichung Hsien 412 Taiwan  
Phone:886-4-2491-7585  
E-Mail:spar@tcts.seed.net.tw

## SP-800A Mixer

### Specifications

#### ● Motor <<<<<

1/4 h.p. (0.20kw), grease packed ball bearing, air-cooled, 110/60Hz, 220/50Hz, Single phase

#### ● Controls <<<<<

Spar Mixer controls are front-mounted to give easy access in cramped kitchen environments. The following controls are standard on all Spar Mixers: separate start and emergency stop buttons so operators can shut down the mixer immediately in an emergency situation, a 15-minute timer which shuts off the machine after set time has elapsed, and thermal overload protection

#### ● Cord and Plug <<<<<

Single phase are hard wired

#### ● Transmission <<<<<

Heat-treated, hardened alloy, precision milled gears operate with planetary action. Gears are packed in a long-lasting, high pressure grease. Planetary gears are driven by an oversized cog-wheel, which is in turn driven by a cogged belt powered by the motor drive shaft. Cogged belt is a long-lasting, rugged fibre/rubber composite. This unique design yields high-torque mixing power while avoiding the high cost encountered repairing direct-drive transmission components.

#### ● Speeds: <<<<<

1. 1st gear 132 rpm
2. 2nd gear 234 rpm
3. 3rd gear 421 rpm

#### ● Bowls and Agitators <<<<<

Standard equipment includes a 8 Qt. (7.6Litres) high quality stainless steel bowl, dough hook, flat beater, and whip. A sturdy hand lever on the body column raises and lowers the bowl as well as locking in place at the top and bottom positions.

#### ● Finish <<<<<

White epoxy enamel

#### ● Shipping Information <<<<<

N.W. 25 kgs  
G.W. 27 kgs

Carton Size: (L x W x H)  
47cm x 28cm x 58cm

Cartons are affixed to an under-sized skid (pallet), the weight and dimensions of this skid are not included above and may vary from shipment to shipment.

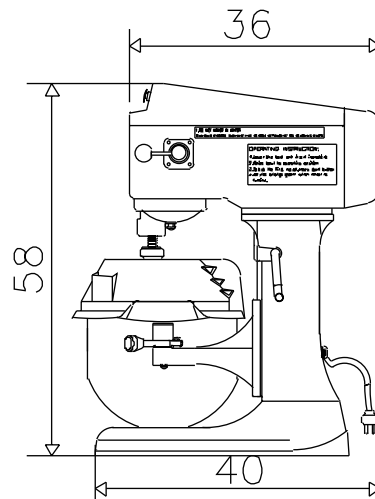
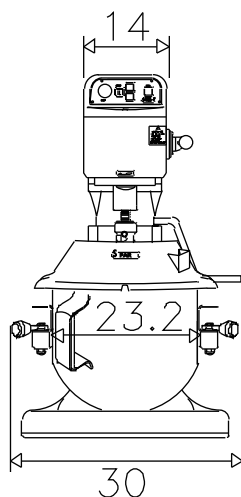

SP-800A <<<<<



## ◆ HI Series

| MODEL              | Capacity  | Hores Power | Voltage<br>60HZ/50HZ          | Weight<br>(N. W.) | L x W x H<br>(cm) | 3-Speeds<br>R.P.M | Extra<br>Accessories | Mincer | Veget |
|--------------------|-----------|-------------|-------------------------------|-------------------|-------------------|-------------------|----------------------|--------|-------|
| SP-500A<br>SP-502A | 5 quarts  | 750W        | 110V/220V                     | 15KGS             | 40 x 31 x 45.5    | 40~260            |                      |        |       |
| SP-800A            | 8 quarts  | 1/4 HP      | 110V/220V                     | 25KGS             | 47 x 28 x 58      | 132.234.421       |                      |        |       |
| SP-100A            | 10 quarts | 1/3 HP      | 110V/220V                     | 65KGS             | 46 x 45 x 76      | 106.196.358       |                      | VH-12  | V99S  |
| SP-200A            | 20 quarts | 1/2 HP      | 110V/220V                     | 80KGS             | 53 x 52 x 87      | 106.196.358       | 10 QT                | VH-12  | V99S  |
| SP-22HA            | 24 quarts | 3/4 HP      | 110V/220V                     | 110KGS            | 56 x 55 x 91      | 108.183.352       | 10 QT                | VH-12  | V99S  |
| SP-30HA            | 30 quarts | 1.0 HP      | 220V/380V                     | 180KGS            | 67 x 55 x 117     | 99.176.320        | 20 QT                | VH-12  | V99S  |
| SP-34HA            | 40 quarts | 1.25 HP     | 220V/380V                     | 190KGS            | 67 x 55 x 117     | 99.176.320        | 20 QT                | VH-12  | V99S  |
| SP-40HA            | 40 quarts | 1.5 HP      | 220V/380V                     | 250KGS            | 75 x 65 x 131     | 99.176.320        | 20 QT                | VH-12  | V99S  |
| SP-50HA            | 50 quarts | 2.0 HP      | 220V/380V                     | 270KGS            | 75 x 65 x 131     | 99.176.320        | 20 QT                | VH-12  | V99S  |
| SP-60HA            | 60 quarts | 3 HP        | 220V/380V                     | 270KGS            | 78 x 65 x 131     | 99.176.320        | 30 QT                | VH-12  | V99S  |
| SP-B80HI           | 80 quarts | 3 HP        | 220V/380V/415V<br>50/60HZ 3PH | 455KGS            | 108 x 79 x 156    | 69.121.204.356    | 40 QT                | VH-12  | V99S  |

Spar Food Machinery Mfg. CO., Ltd.

No.145, 11th Industry Rd. Ta-Li City, Taichung Hsien 412 Taiwan

TEL : 886-4-2491-7585

FAX : 886-4-2491-7565

E-MAIL : spar@tcts.seed.net.tw

http://www.sparmixers.com